

HVM 025-XXX-X260-4G-BY

Page 1/5

Electrohydraulic servovalve for bypass-operation

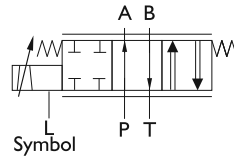
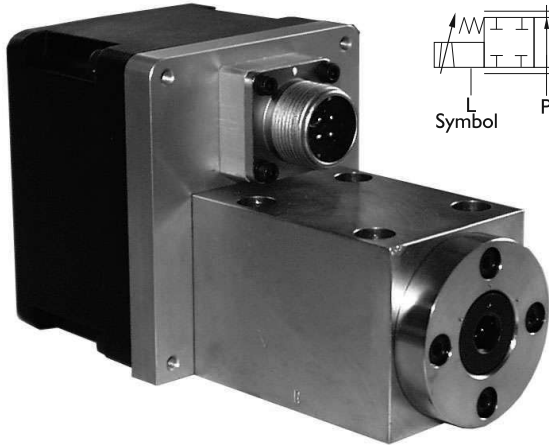

Special features:

- work with 1 or 2 metering edges
- high reliability
- easy service
- robust construction
- high dynamic response
- relatively insensitive to contamination
- variable metering orifices only
- $p_{max} = 500$ bar

General description:

Type	:	electrical input stage, torque motor, sliding spool system
Pilot	:	none
main spool	:	directly controlled sliding spool
Style of mounting	:	subplate
Mounting position	:	unrestricted
Weight	:	1,3kg

Technical Data

1. Hydraulic Data (definition according to DIN 2431 I)

.1	operating pressure	$p_{b \text{ min}}$ (for operating)	=	0...500	[bar]	*at > 25cSt
					500	[bar]
.1.1	return line pressure	$p_{r \text{ max}}$	=	500	[bar]	adds itself too $p_{b \text{ min}}$
.2	rated flow at max. pressure (static test pressure)	p_{max}	=	500	[bar]	
.3		$Q_{\text{bei } 0\text{mA}}$	=	0,5	[l/min]	at 1 metering edge
		Q_N at Rated current	=	1 / 3 / 5	[l/min]	(see flow curve)
.4	internal max. leakage (Lecköl)	Q_L	<	5	[cm ³ /min]	
.5	hysteresis	H	<	4,5% i_N	(without Dither)	
				2% i_N	(with Dither)	
.6	threshold sensitivity	E	<	0,2% i_N	(without Dither)	
				0,1% i_N	(with Dither)	
.7	threshold span	S	<	1,5% i_N	(without Dither)	
				1% i_N	(with Dither)	
.8	operating temperature range		=	253...353	[K]	
.8.1	temperature drift			2% i_N / 50K		
.9	viscosity range of fluid		=	10...1000 mm ² /s approximate value normal: ISO VG 10...ISO VG 46		
.10	filtration of fluid		<	class 4-5	to NAS 1638 or	
				class 15/14/11	to ISO 4406	
.11	fluid standard		=	HLP-hydraulic oils as per DIN 51524 Teil 2 (Special equipments possible)		

See also data sheet HVM 025

HVM 025-005-XX60-4G-BY

Page 2/5

2. Characteristics HVM

Pressure characteristic

(1 connection: $P > A$, or $B > T$)
 at Q constantly 3.6 l/min.
 (operating medium brake fluid DOT 4)

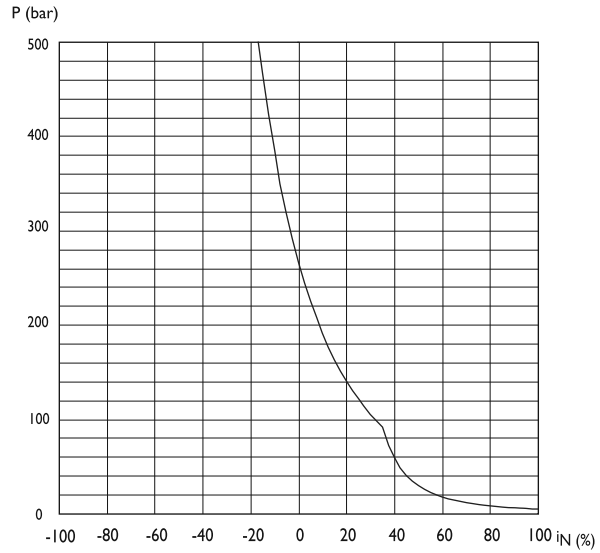

Pressure characteristic

(2 connection: $P > A$ and $B > T$)
 at Q constantly 3.6 l/min.
 (operating medium brake fluid DOT 4)

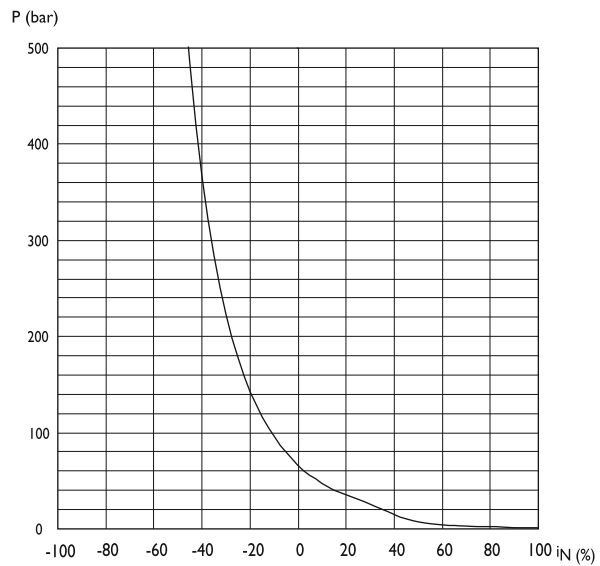

HVM 025-XXX-X260-4G-BY

Page 3/5

2. Characteristics HVM

Flow characteristic

at

single flow
 connection: P > A, or B > T
 (operating medium brake fluid DOT 4)

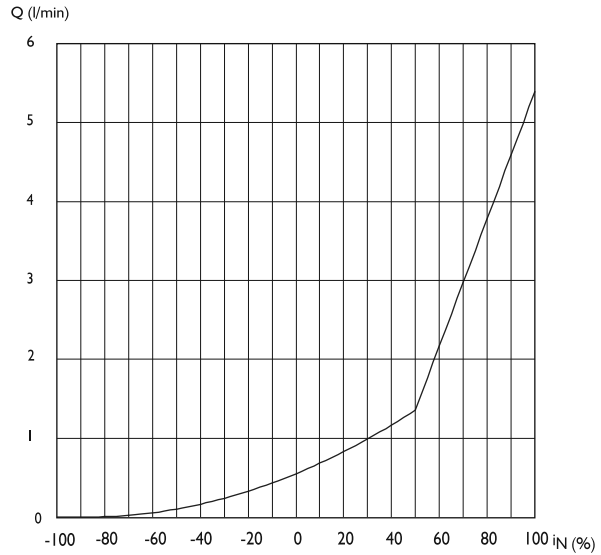

Flow characteristic

at

double flow
 connection: P > A and B > T
 (operating medium brake fluid DOT 4)

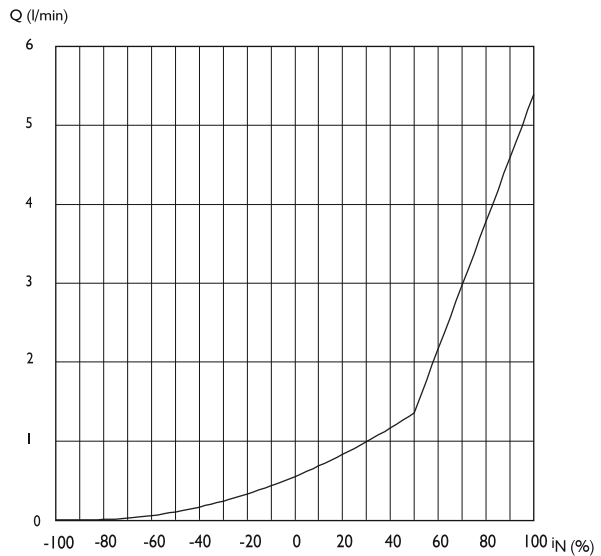

HVM 025-005-XX60-4G-BY

Page 4/5

3. Electrical Data

3.1 Electrical Data without Electronic

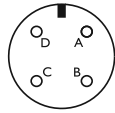

connector 4 pol.
DIN 43563

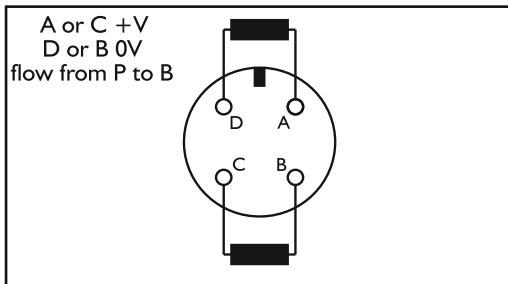

coil type		inductance	rated current	resistance	power
1	1 coil	86 mH	± 325 mA	11,5	1,35 W
	2 coil parallel	31,2 mH	± 650 mA	6	2,7 W
2	1 coil	320 mH	± 150 mA	60	1,35 W
	2 coil parallel	157 mH	± 300 mA	30	2,7 W

3.2 Electrical Data with Electronic

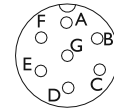

connector 7 pol.
DIN 43563

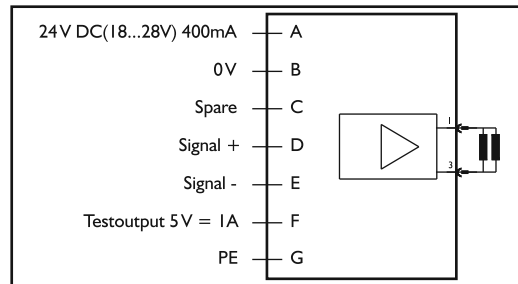

Input	E1	E2	E3	E4	Flow
Signal D > E	+ 10V	4 mA	20 mA	+20 mA	P>A
	0V	12 mA	12 mA	0 mA	0
	- 10V	20 mA	4 mA	-20 mA	P>B

Example of Application Bypass-Double-Flow-Operating System

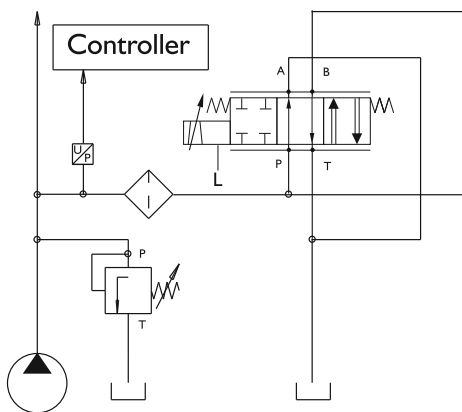

HVM 025-XXX-X260-4G-BY

Blatt 5/5

Order Information

HVM 025 - 005 - XX60 - 4G - BY - E

Model

025 (Schneider)

Rated flow

QN bei
001 / 003 / 005 l/min

Seal material

- 1 Perbunan
- 2 Viton
- 3 Butyl
- 4 Vulkollan
- 5 Ethylen-Propylen

Resistance / coil [R20]

2 60

overlap

6 asymmetrically edgetuning

Amount of overlap

assigned by manufacturer

Design letter

assigned by manufacturer

Special valve spool

for pressure control in the bypass
pressure ports P+B
pressureless ports A+T

Elektronik

- E1 Voltage input $\pm 10V$
- E2 Current input 4...20mA P nach A
- E3 Current input 4...20mA P nach B
- E4 Current input $\pm 20mA$

5. Accessories:

Description		Order No.
Connector 4pol.	KE CA 06COM E 14 S2S	13018
Sub plate	HZ 02	11589
scavenger plate	HZ 028	12396
Double flow plate with integrated high press filter	HZ 093	23917
Box-Amplifier	BOE 300-025-X-X-XX	
Digital-Amplifier	HE 303/ HE 304	

Important remarks:

Valve mounting surface must be flat within 0,02mm and smoothness not to exceed 6µm. Easy hydraulic Zero adjustment by means of Allen key S8 DIN 911. Max. permissible drain line pressure 10 bar. Valves with modified characteristics available. Modifications, which serve technical progress, remain reserving.

Für diese Vorlage bzw. Vorschrift techn. Art behalten wir uns alle Rechte vor. All rights reserved for this document (vgl. DIN 34)

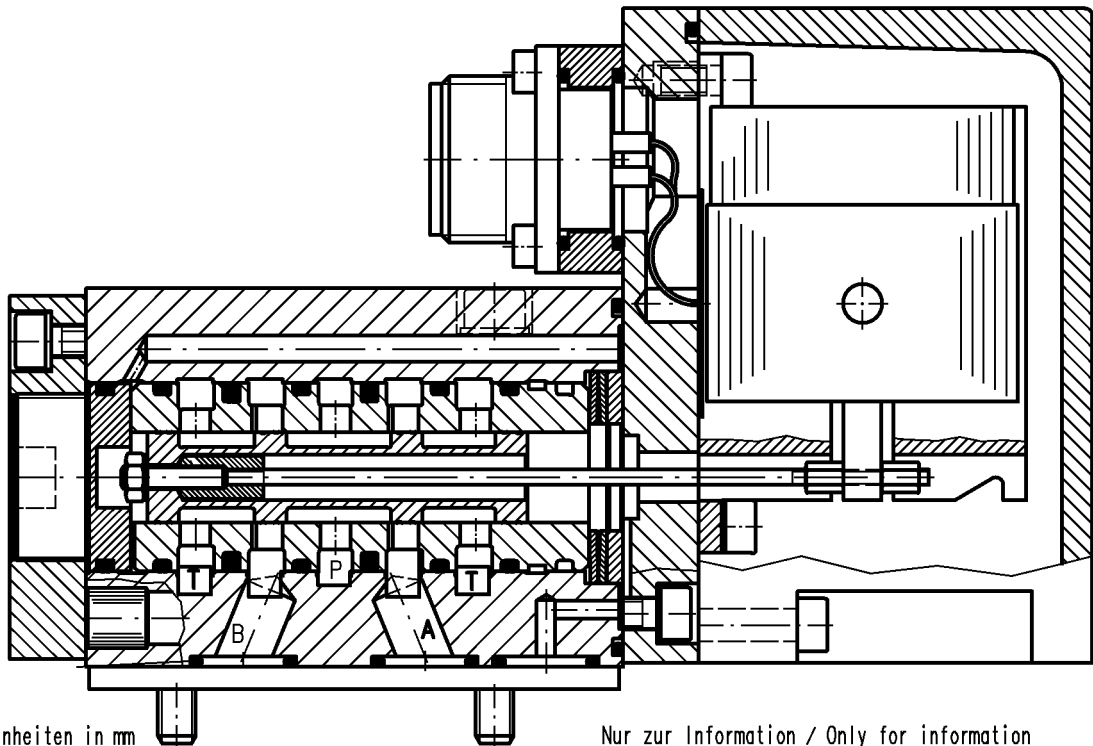
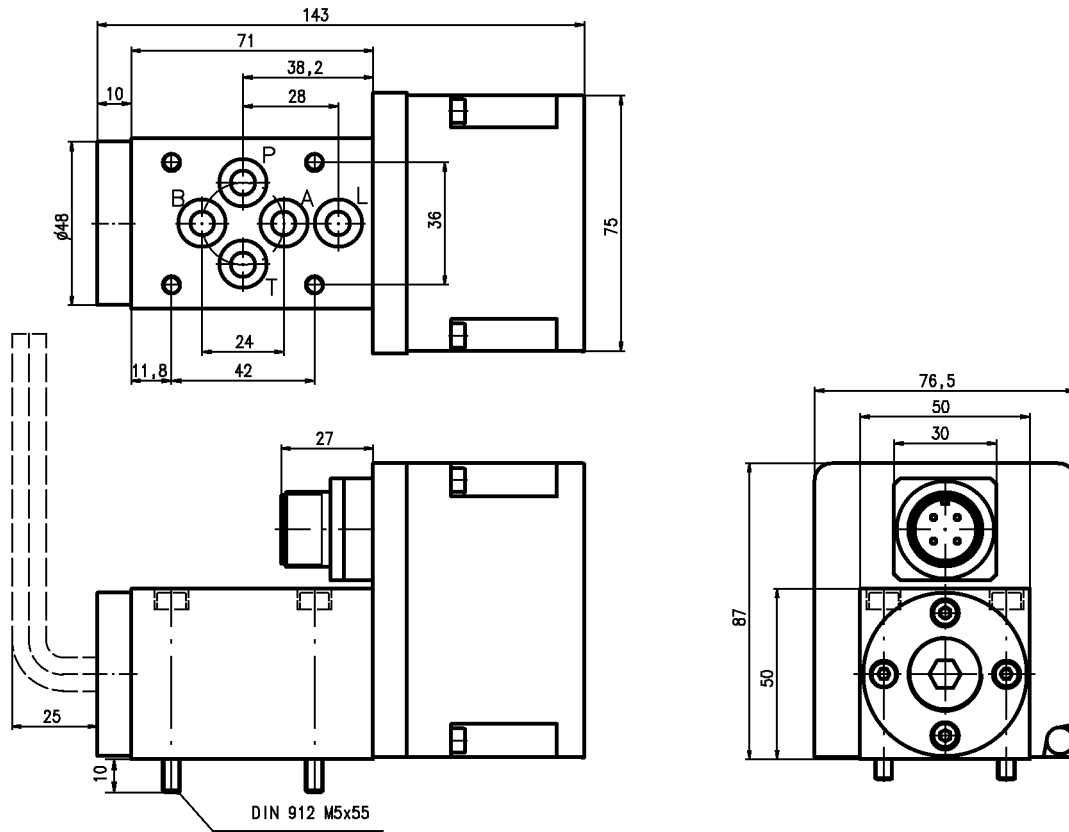

Angaben ohne Einheiten in mm
All dimensions without unit in mm

Nur zur Information / Only for information

Änderungsindex / Amendment index		
	Datum Date	Name Name
dwg.	15.07.03	Dindorf

Ventil
Valve

HVM 025-005-XX60-4G-BY

Id.- Nr.
-

Jos. Schneider Optische Werke GmbH
 Ringstr. 132 55543 Bad Kreuznach
 Germany

