

SCHNEIDER SERVOHYDRAULIC

Digital axis controller Type HE 303

Description

The digital axis controller HE 304 is a μ C-based regulator with analogue, digital, sensors and different bus inputs and outputs in a compact design. He is useable for all electro hydraulic axis and all fast regulators in industrial und testing applications.

Application types are as

- Electro hydraulic axis
- Position control
- Parallel control
- Force/pressure controls
- Force control with subordinated position control
- Position control with delimited force

An analogue exit is directly suitable for the current control of the servo valves. A digital sensor input is laid out as SSI and/or start-stop interface for common position sensors. According to standard a CAN bus, optionally still another further bus connection as Profibus or Interbus are present. With the HE 304 1(2) hydraulic servo axis can be regulated. With the HyperTerminal Windows program (included in each Windows system) the parameter to the controller can be set. On request, the software can be adapted customized. (e.g. desired value process; limit switching points; drive external devices etc.

Execution variants

The mainboard is delivery as a junction box for field application up to protection level IP65 or in a rail mountable version for electric cabinet mounting. In addition, a 19-zoll European size cards for rack mounting is delivery also (see data sheet HE304).



Bloc diagram

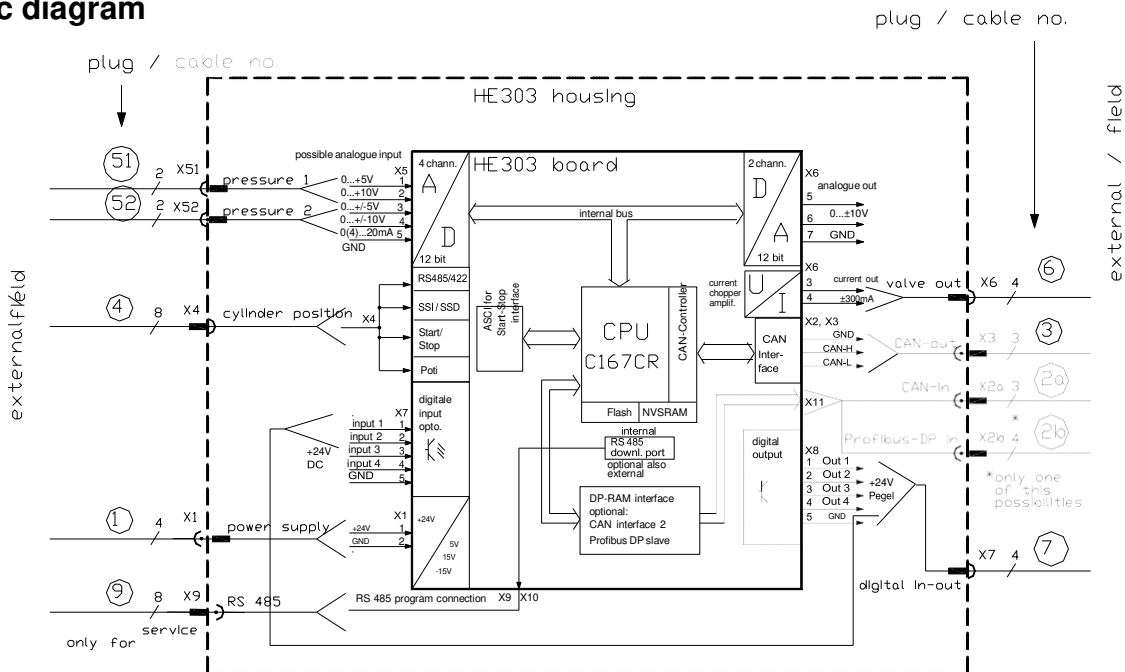

Technical data

Supply

Power supply unipolar : 24V DC ($\pm 15\%$) approx. 500mA

Inputs

Digital

Digital inputs $D_{in} 1 - 4$: 24 Volt opto isolated
input current = 10 mA
1-Signal $U_e > 12 V$ 0-Signal $U_e < 5 V$

SSI, SST (Start/Stop) input for position sensors

: transmit $I_{max} = \pm 60mA$
receivers sensivity $\pm 200mV$

CAN-Bus-input

: $U_{CAN} = -5 \dots +18V$
: $U_{diff} = 1,5 \dots 3V$, short circuit resistance
max Baud-Rate: 500kBaud
terminal resistance 120 Ohm; plug able

Profibus-Slave input

: (with additional add-on board)
according to Profibus-DP EN 50170 (DIN 19245)

Programming interface

: RS422 (RS232 with add-on modul)
: transmit $I_{max} = \pm 60mA$
receiver sensivity $\pm 200mV$
: RS232 (with type HE304 or with add-on modul)

Analogue

Analogue input 1 - 4 : 12 bit resolution
0...+ 10V ; $\pm 5V$; $\pm 10V$; 0...+5V; selectable; $R_{in} 30 kohm$
or as current inputs 0/4-20mA plug able
 $R_{in} 250 Ohm$

Outputs

Digital

Digital outputs $D_{out} 1 - 4$: 24 Volt / 500 mA,
short circuit resistance; with reference to internal GND

Analogue

Analogue voltage $U_{out1} / 2$: 0... ± 10 Volt, 12 bit resolution
 $I_{max} 5mA$; short circuit resistance

For servo valve

: PWM current booster with dither

Possible rated currents

: 0 ... $\pm 200 / \pm 300 / \pm 650 / \pm 1000mA$
short circuit resistance

Controller

Micro controller 16 bit : Siemens C167 with 20 MHz
Controller scan time : 1 ms with watchdog control
Parameter interface : with RS232
Storage capacity : Flash EPROM 256 x 16
NVRAM 2 x 32k x 8

Mechanical data's

Dimensions : 160 x 100 x 50 mm
Weight : approx. 500 g

Environment

Permissible storage temperature	: -40 ... +85 °C
Permissible humidity	: 30 ... 75 % not condensed
Shock resistance	: <2g sinus form 10 ... 100Hz
EMC level	: 3 according to EN 50082-2

Junction case model (1)

Permissible ambient temperature	: -10°C ... +65°C
Connector	: M12 Sensor connector 4–8 pin
Protecting class	: IP65

Rail mounting modul (2)

permissible ambient temperature	: 0°C ... +55°C
Connector	: Micro-Combicon connector with spring

Type model and order codes

40067	HE 303- XXXX – 1	01	00	1 –	0 A	
order no.	Type 303	current xxxx 0200 0300 0650 1000	housing-Type 1 = junction case 2 = rail mount	Software-Type 00 = basis model 01 = customer ... 99	hardware type 00 = only board 01 = connector types 99	add on boards 0 = without 1 = Profibus 2 = external CAN-open 3 = RS 232 4 = +/-12V & RS232
					construction level 0A = 3/2003	

Executed samples

order no	Type	description
12363	HE 303-xxxx-1-01-02-3-0A	Standard digital control
22550	HE 303-0300-1-01-01-0-0A	CAN-BUS REGLER
39251	HE 303-0300-1-01-01-1-0A	PROFIBUS-REGLER
21263	HE 303-0300-1-03-02-1-0A	position control with SST-input
14206	HE 303-0200-1-04-02-3-0A	cylinder control 4-20mA
19354	HE 303-0300-1-06-02-3-0A	Start-Stop position control
10244	HE 303-0300-2-07-00-0-0A	St-Stop positions-force control
10147	HE 303-0300-2-08-00-1-0A	position-force control

Additional parts

21945	KE 6xM12-303-Satz	M12 cable set for junction case model
13066	KE M12-303 RS232	programming cable M12 to D-Sub 9pin

Connection

Connection cable size:

For supply (X1) 0,5mm² up to max 1,5mm²
 For all other connections 0,14mm² up to 0,5 mm²

X1	<u>power supply</u>		
X1.1	+24V		
X1.2	GND		
X2/X3	<u>CAN Bus</u>	X7	<u>Digital input</u>
X2.1	GND (option from external)	X7.1	input 1
X2.2	CAN-L	X7.2	input 2
X2.3	CAN-GND	X7.3	input 3
X2.4	CAN-H	X7.4	input 4
X2.5	+24V (option from external)	X7.5	GND (potential isolated)
X4	<u>SSI or SST Sensor input:</u>	X8	<u>Digital output</u>
X4.1	Rx-	X8.1	output 1
X4.2	Rx+	X8.2	output 2
X4.3	Tx+	X8.3	output 3
X4.4	Tx-	X8.4	output 4
X4.5	+24V supply sensor	X8.5	GND internal
X4.6	GND sensor	X9	<u>Programing interface</u>
X5	<u>Analogue input</u>	X9.1	Tx+
X5.1	channel 1	X9.2	Tx-
X5.2	channel 2	X9.3	Rx+
X5.3	channel 3	X9.4	Rx-
X5.4	channel 4	X9.5	GND
X5.5	analogue GND	X11	<u>Subprint Profibus</u>
X6	<u>Analogue output</u>	X11.1	+5V Bus (*)
X6.1	+24V supply for externals	X11.2	GND (*)
X6.2	GND	X11.3	A-Line
X6.3	Servo + (current out)	X11.4	B-Line
X6.4	Servo-	X11.5	screen
X6.5	Analogue out 1 0...±10V	X11.6	RTS (*)
X6.6	Analogue out 2 0...±10V		
X6.7	GND (reference)		

(*) normally one does not need

Layout diagram

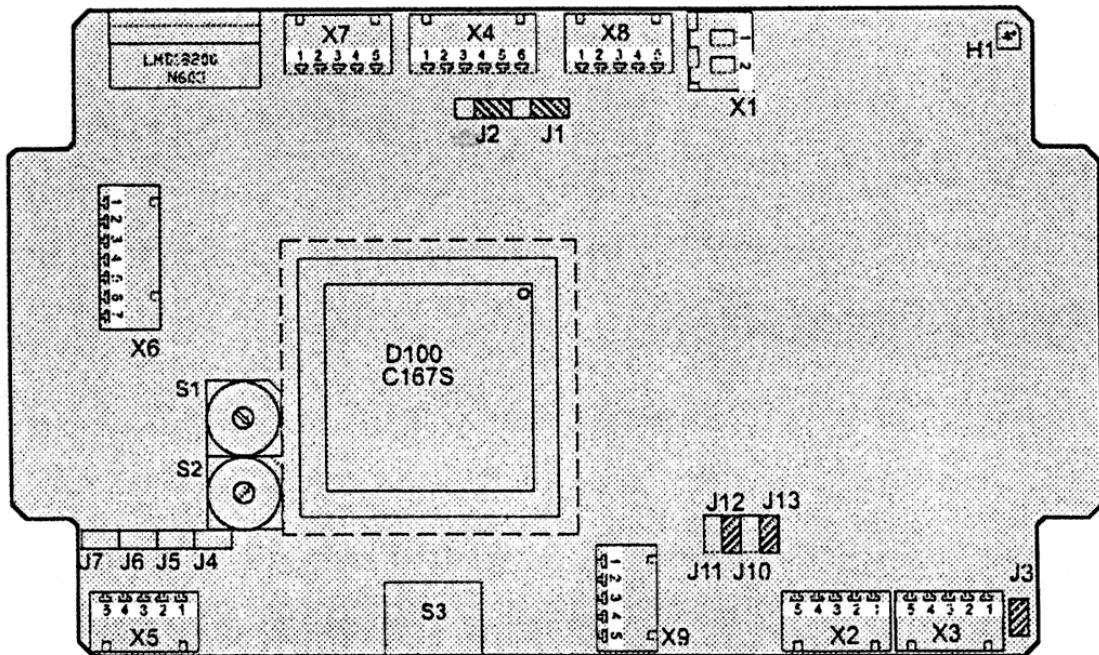

Jumper settings

J1...J2	SSI / Start-Stop (above)		
	J1 and J2	right =	for SST-sensor (Start-Stop-sensor)
	J1 and J2	left =	for SSI-sensor
J3	CAN terminal resistance (down completely right)		
	J3	out = open	in = with 120 Ohm
J4...J7	analogue current / voltage input selection (down left)		
	J4	out = voltage	in = current for channel 1
	J5	out = voltage	in = current for channel 2
	J6	out = voltage	in = current for channel 3
	J7	out = voltage	in = current for channel 4
J10...J11	diagnostic port setting (down right)		
	J10 and J11	out = Full-Duplex	in = Half Duplex
J12...J13	diagnostic port setting (down right)		
	J12 and J13	out = open	in = with 120 Ohm
S1 / S2	CAN address		
	S1	CAN low	S2 CAN high
S3.1-4	4 chan. DIP-switch cold boot / download / Baud rate (down, middle)		
S3.1	0 = Run	1 =	Reset
S3.2	0 = Run	1 =	Download Modus
S3.3/4	Off / Off = 125 KB	On / Off =	250 KB
	Off / On = 500 KB	On / On =	1000 KB
Led H1	(top right)		
	off = no voltage	flashing with 1 Hz = run (or download run)	on = stop