



Schneider
Servohydraulics



Power Amplifier BOE XXX-30

Highest *Quality*,
high reliability and easy
servicing.



CONTENT

1.	Manufacturer's declaration	3
2.	General notes	3
3.	Intended use	4
4.	Safety and hazard information	4
5.	General information on initial operation	5
5.1	Information regarding the wiring	5
5.2	Information regarding the voltage supply	6
5.3	Front view	6
6.	Advantages and features of the power amplifier	7
7.	Information on operation	7
7.1	Functional description	7
8.	Settings	9
8.1	Input signals: DIP switch settings	9
8.2	LED definitions	10
8.3	Zero point adjustment (P1)	10
8.4	Adjusting the valve current (P3)	10
8.5	Dither settings	11
9.	Technical data	13
9.1	Block circuit diagram	13
9.2	Plug assignments	14
9.3	Dimension sheet	14
10.	Type code	14
10.1	Structure	14
10.2	Technical data	15
10.3	Order numbers	15

First edition English 12/2018

All rights reserved. No part of this publication, including excerpts, may be reproduced in any form or processed by any means, including electronic, mechanical, or chemical processes, without the written permission of the publisher.

This document may contain printing or typographical errors. The information in this document is reviewed and corrected at regular intervals and corrections are included in the next issue.

No liability is assumed for errors of a technical or typographical nature or their consequences.

All intellectual property rights and trademarks are recognized. Subject to modifications in the interests of technical progress.

Power Amplifier BOE XXX-030

Servo valves and electronic assemblies represent the core of all electro-hydraulic control systems. Compliance with static and dynamic characteristics requires top-quality equipment.

SCHNEIDER-Servohydraulics servo valves and electronic assemblies meet these requirements by providing 100% quality control, high reliability and ease of servicing.

1. Manufacturer's declaration

We hereby declare that the product described is intended for installation in a machine or device and that initial operation is prohibited until it has been determined that this machine or device complies with EU directives.

The device may be installed and put into operation only by a specialist who is familiar with the device!

Those who complete a machine or make a component ready for operation extension or installation of the device are considered a manufacturer in accordance with the relevant directive and are obliged to provide all accompanying documents with the transfer of the device and also to provide their name and address.

2. General notes

Please adhere to all instructions in this document. Only then is trouble-free operation of the device possible. In the event of non-compliance, no warranty shall be assumed for any damage incurred.

Opening of the devices within the warranty period is only permitted after contacting and obtaining approval from the manufacturer.

The operation, technical characteristics, and the service life of the device depend on the conditions under which the device is operated and are limited by wear or aging.

The user of the system is responsible for periodic inspections and maintenance of the equipment. On request, a loan device can be provided for the duration of the inspection by contacting the manufacturer.

Power Amplifier BOE XXX-030

3. Intended use

The power amplifier is used to control electro-hydraulic servo valves in a closed control circuit. In this case, analog signals (current or voltage signals) of a higher-level control system are converted into control signals for servo valves. Information pertaining the entire system can be found in the corresponding documentation.

The power amplifier is not to be used for purposes that deviate from the intended use. Compliance with the technical specifications given in this manual is essential and mandatory. Damage may result if these values are exceeded. In this case, no liability is assumed.

4. Safety and hazard information

The currently applicable VDE regulations must be observed when handling products that come into contact with electrical current.

Temperatures can be reached on the surfaces of electrical and/or hydraulic components during operation that could cause skin burns.

Before installation or maintenance work, make sure that the hydraulic system is depressurized and the device is deenergized.

If this description does not clearly indicate to the end user which characteristic values apply to a component or assembly, how to wire the device externally or which external components or accessories may be connected and which connected loads these external components may have, then always consult a specialist for further information.

Before initial operation of the device, it must be determined if this device or this component is suitable for the application for which it is to be used! When in doubt, it is absolutely necessary that you consult specialists, experts, or the manufacturer of the components used!

Please note that since operating and connection errors are beyond our control, we understandably cannot assume liability for any damage.

Before initial operation of the equipment, check that the components are correctly connected to prevent a malfunction.

Always inspect live cables to which the device, component, or assembly is connected for damage.

If a fault in the supply lines or on the device is detected, the device must be taken out of service immediately and secured against unauthorized use until the defective cable has been replaced.

A defect in the power amplifier could lead to uncontrolled operation of the device and thereby result in an increased risk of accidents. The user must take appropriate protective measures.

- All wiring work may only be carried out when the device is deenergized. The user must take appropriate measures, since there is always a risk of fire while operating electrical components.
- The amplifier must not be used in a potentially explosive atmosphere.
- Do not cover the vents to ensure that the device is adequately cooled.
- Dispose of the device according to relevant national regulations.
- The amplifier is to be protected against the effects of weather, contamination, and physical damage.
- Liability shall not be assumed for any damage resulting from non-compliance with these instructions.

5. General information on initial operation

The amplifier is designed for installation in a shielded EMC housing (control cabinet). All cables leading to the outside must be shielded, and complete shielding is assumed. There should be no strong sources of electromagnetic interference near the amplifier.

5.1 Information regarding the wiring

The amplifier is to be mounted and wired as indicated in the documentation and according to EMC requirements. Starlayout grounding is recommended if other consumers are operated on the same power supply. Adhere to the following items when wiring:

- The signal cables must be installed separately from power cables.
- Analog signal lines must be shielded.
- All other cables should be shielded if there are strong sources of interference and if cables are longer than 3 meters. Split ferrites should be used if there is high frequency radiation.

Power Amplifier BOE XXX-030

5.2 Information regarding the voltage supply

The voltage supply must be a regulated power supply. The low internal resistance of regulated power supplies allows for better interference voltage dissipation, which improves the signal quality. Switched inductors (such as relays and valve coils) on the same power supply must **always** be wired with a corresponding overvoltage protection directly at the coil.

5.3 Front view

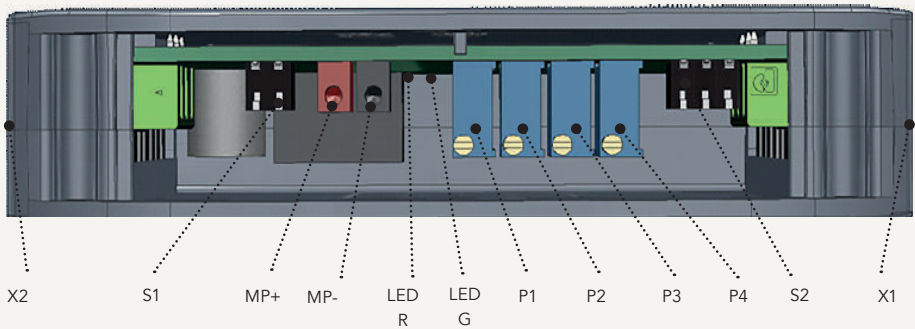

Legend

- | | |
|-----------|------------------------------------|
| X1 + X2 | Connector plugs |
| S1 & S2 | DIP switches |
| MP+ & MP- | measuring points (red + / black -) |
| P1 | Zero point |
| P2 | Dither amplitude |
| P3 | Valve current |
| P4 | Dither frequency |



6. Advantages and features of the power amplifier

SCHNEIDER-Servohydraulics power amplifiers are characterized by a reliable, consistently high standard of quality. The technical design of the design offers decisive advantages for industrial use:

- Electronic fuse – shutdown at excessively high temperatures or in the event of short circuits. Automatic fuse reset.
- Various input signals, current or voltage, adjustable via DIP switch
- Rated current 100...1000 mA infinitely adjustable, custom models! 10...100mA
- Infinitely variable adjustment of dither amplitude and dither frequency
- High accuracy current measurement with 0.05% resistors
- Valve current measurable as voltage $10V = 1000mA$
- Offset/zero-point adjustment
- Compact design
- Can be mounted on a top hat rail
- High operational reliability

7. Information on operation

7.1 Functional description

The current amplifier is designed as a pulse-width modulated (PWM) H-bridge amplifier for driving inductive loads and is controlled by an analog signal from a higher-level control. The high chopper frequency makes the amplifier ideal for dynamic servo valves.

There are two DIP switches behind a hinged cover for setting the commonly used input signal, as well as measuring points and potentiometers for setting the rated current/zero point and the dither. A green LED indicates operational readiness; a red LED indicates a possible error.

The connection is made via two 3-pin plug contacts (X1 & X2) Adjustments to various servo valve rated currents are possible. The output current is regulated and the maximum level can be adjusted using potentiometer P3. The direction of action can be rotated by changing the polarity of the electrical valve connections. The zero position can be adjusted using potentiometer P1.

Power Amplifier BOE XXX-030

The current output is intended for feeding valve coils.

Pure ohmic loads cannot be operated.

The output current can be adjusted using potentiometer P3 from ± 100 to ± 1000 mA. Optionally, the amplifiers can also be supplied with an output current in the range of ± 10 to ± 100 mA or equipped with an additional heat sink up to 2A.

Any necessary dither signals for the servo valves can be set. The amplitude size can be adjusted using potentiometer P2 and the frequency can be adjusted using potentiometer P4. The dither signal is added to the output signal.

The output shuts off in the event of a short circuit or an excessively high temperature. This is indicated by a red LED. Once the error is corrected, the amplifier automatically switches back on.

If the ambient temperature is greater than 55°C and the current is constantly too high (> 650mA), the amplifier may become too hot and switch off. The amplifier automatically switches back on once it cools down again.

8. Settings

8.1 Input signals: DIP switch settings

Type code	Input signal	S1 (2-pin)		3	S2 (3-pin)	
		2	1		2	1
	Factory setting Item no. 1061031	off	off	off	off	off
0	Voltage 0...+/-10V	off	off	off	off	on
1	Current 0..10..20mA	on	on	off	on	off
2	Current 4..12..20mA	on	on	on	off	off
3	Voltage 0..5..10V	off	off	off	on	off
6	Current 0..+/-20mA	on	on	off	off	on

Note: Signal input – (X1 pin 1) and supply GND (X1 pin 3) must be connected with low resistance. If the full standard signals are not available (for example, only +/-5 V), it is possible to adjust the corresponding nominal current with potentiometer P3.

Power Amplifier BOE XXX-030

8.2 LED definitions

Green LED	Supply voltage OK – ready for operation
Red LED	Short circuit or high temperature

8.3 Zero point adjustment (P1)

Preparatory work:

Connect amplifier with valve electrically, apply hydraulic pressure to port P.

Procedure:

Adjust potentiometer P1 until the hydraulic zero point is reached, i.e. the downstream actuator – motor or cylinder – maintains its position (close to standstill). It is practical to make these settings at operating temperature.

Control:

After a trial modulation of the valve, the actuator must come to a standstill again with signal „0“. Movement speed: $< 1\% V_{max}$

8.4 Adjusting the valve current (P3)

The maximum valve current is set at potentiometer P3. The adjusted current is conducted via a high-precision shunt and can be measured at the measuring points MP + and MP-.

Scaling: $10V = 1000mA$

8.5 Dither settings

Using dither

Reducing the valve hysteresis

According to established mechanical principles, moving out of a stationary position has greater friction (static friction) than the friction of an already moving mass. This also applies to the inner piston of a servo valve. Therefore, all amplifiers for servo and proportional valves have a dither adjustment option. An optimal dither setting increases the control accuracy in the closed control circuit and thus the reliability of the hydraulic system.

Reducing the sensitivity to contamination

With the small oscillation movement of the piston, dirt particles can pass through the piston, which without dithering would adhere to the piston after a short time. This is especially important in static applications. In dynamic applications, dither is not typically needed.

Measuring the dither signal

An oscilloscope with a corresponding probe is required for qualified measurement. The dither can also be measured without an oscilloscope at the test points with a commercially available multimeter using the AC measuring range. The approximate conversion values are shown in the table.

Potentiometer turns n	1	2	3	4	5	6	7	8	9	10	11	12	13	14
AC [mV]	5	10	20	40	60	80	95	107	110	115	120	125	130	135
%	0.3	0.7	1.3	2.7	4.0	5.3	6.3	7.1	7.3	7.7	8.0	8.3	8.7	9.0

Power Amplifier BOE XXX-030

Practically setting the dither amplitude

The influence of the dither amplitude is very dependent on the oil pressure and the amount of oil in the actuator. Under certain circumstances, there may also be mechanical resonances between the dither amplitude and the transit time in the pipeline. Because of these dependencies, it is difficult to make a general recommendation for the dither amplitude. We recommend 1% to 3%.

Setting the dither amplitude

The dither is generated as an AC voltage and added to the analog signal input. The factory setting is 1%.

The adjustment range is 0 to 10% with respect to the rated current of the servo valve at 100% input signal. The dither amplitude can be adjusted with the 15-turn potentiometer P2.

For the recommended setting range, see the values highlighted in light grey in the table.

Using the dither amplitude for valve cleaning

A slow deterioration of the control behavior or the resolution of the system can be an indication of valve contamination. Set the amplitude to 100% for about 5 minutes to remove these possible deposits on the piston with the aid of the dither amplitude. However, it should be ensured that no hazardous conditions can arise on the machine. If this action shows an improvement in the control quality, there was a problem of contamination. Determine the cause. To remedy the contamination problem in the long term, the oil should be properly changed or cleaned.

Contamination level	class ISO 4406	NAS1638
For function	class 15/12	class 6
To achieve the characteristic values	class 14/11	class 5
For maximum requirements	class 12/9	class 3

Disadvantages of an excessively high dither amplitude

An excessively high dither amplitude can cause the piping to vibrate and eventually break off. Note: Excessively high dither amplitude combined with poor oil quality accelerates wear.

Setting the dither frequency

The dither frequency is preset to approximately 200 Hz. At this setting, the internal valve piston can oscillate, but larger masses such as cylinder pistons cannot follow this frequency. Should there be problems with the control, for example due to interference with other frequencies, the dither frequency can be changed with potentiometer P4. The frequency range is adjustable from 40Hz to 500Hz.

9. Technical data

9.1 Block circuit diagram

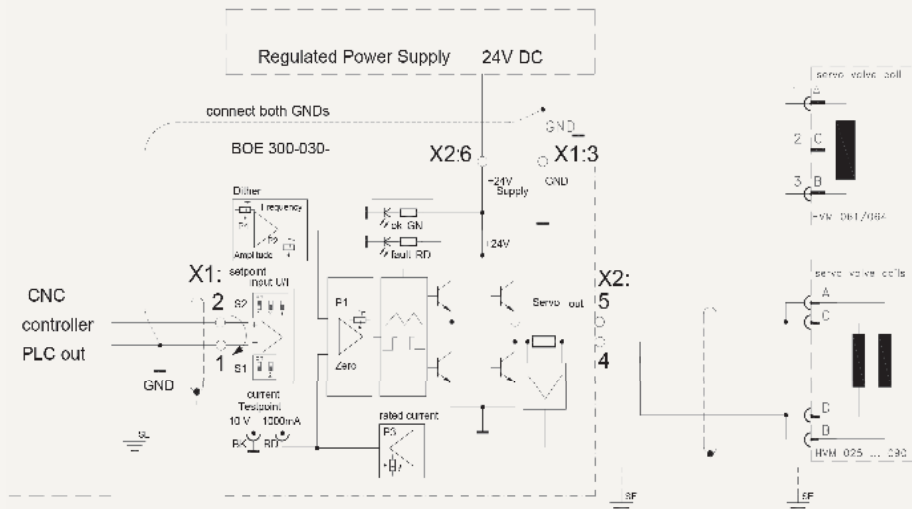

Power Amplifier BOE XXX-030

9.2 Plug assignments

Plug X1 Pin 1	negative signal input (connect to GND)
Plug X1 Pin 2	positive signal input (current input)
Plug X1 Pin 3	supply ground (GND)
Plug X2 Pin 4	servo valve (A,C)
Plug X2 Pin 5	servo valve (B,D)
Plug X2 Pin 6	Supply voltage +24V DC

9.3 Dimension sheet

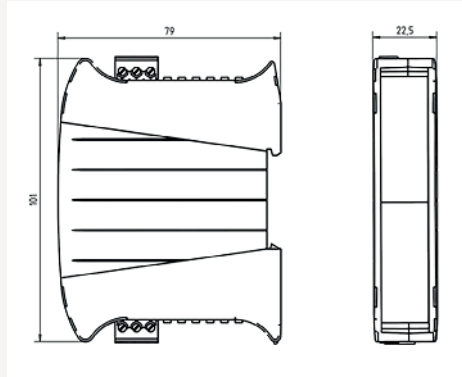

10. Type code

10.1 Structure

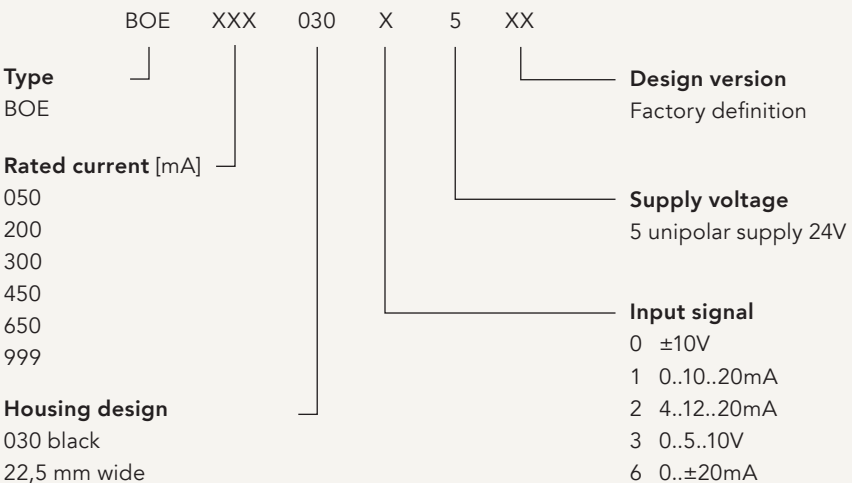

10.2 Technical data

Supply voltage (U _b) Maximum power requirement Power consumption External protection	[VDC] [W] [mA] [A]	18...28 25 depending on current setting 50 plus valve current 1,5 slow-blow
Analog inputs depending on switch position: Voltage Current	[V] [mA]	+/-10 0...10; 100KΩ 0/4...20 -20...20 -10...10
Output to the valve Max. load resistance	[mA] [Ohm]	+/-100...+/-1000 (adjustable) 23 (for max. current)
Dither frequency Dither amplitude	[Hz] [%]	20 to 300 0...10
Housing Dimensions L x W x H Recommended row spacing	[mm] [mm]	ABS, polycarbonate 101 x 22,5 x 79 30
Protection class Temperature range Storage temperature Humidity	[°C] [°C] [%]	IP 20 -20...50 -20...60 < 90 (non-condensing)
Connectors		Two 3-pin connection blocks – pluggable
Weight	[kg]	0.075
EMC		EN 61000-6-2: 2005 EN 61000-6-4: 2007

10.3 Order numbers

ID no.	Type	Note
1061031	BOEXXX-030-X-5-XX	Current and input signal not preset
1092567	BOE050-030-0-5-XX	
1092568	BOE200-030-0-5-XX	
1092569	BOE300-030-0-5-XX	
1092570	BOE450-030-0-5-XX	
1092571	BOE650-030-0-5-XX	
1092572	BOE999-030-0-5-XX	
1092584	BOE999-030-6-5-XX	

ID no.	Type	Note
1092573	BOE050-030-2-5-XX	
1092574	BOE200-030-2-5-XX	
1092575	BOE300-030-2-5-XX	
1092576	BOE450-030-2-5-XX	
1092577	BOE650-030-2-5-XX	
1092578	BOE999-030-2-5-XX	
1092579	BOE050-030-6-5-XX	
1092580	BOE200-030-6-5-XX	
1092581	BOE300-030-6-5-XX	
1092582	BOE450-030-6-5-XX	
1092583	BOE650-030-6-5-XX	
1092584	BOE999-030-6-5-XX	

Other combinations available on request.

Schneider Servohydraulics GmbH
Südstraße 4 | DE-32457 Porta Westfalica

Geschäftsführung: Gerrit Ruppel

T +49 (0) 5731 8692 950
office@schneider-servohydraulics.com
www.schneider-servohydraulics.com

All data without guarantee.
Subject to change without notice.

We accept no responsibility for any errors
and reserve the right of modification without
further notice.

© Schneider Servohydraulics GmbH